

电气特性:

1. 额定电压: 125 VAC RMS
2. 额定电流: 1.5 AMPS@25°C
3. 接触电阻: 20mΩ MAX.
4. 绝缘电阻: 1000 MΩ MIN. @500 VDC
5. 耐压强度: : CONTACT TO CONTACT : 1000V DC OR AC PEAK;  
: CONTACT TO SCREEN AND TEST PANEL : 1500V DC OR AC PEAK  
@0.5mA 50Hz 或 60Hz 一分钟.

REV. 版本	ECN NO. 变更说明	DATE 日期
03-06	ADD P/N	2010.11.27
07	EC13111807	2013.11.18
08	此页未变更	2014.05.10
09	增加料号	2014.07.01

机构特性:

1. 塑壳材质: PBT/PA66/PA46, UL94V-0;
2. 圆针材质: 磷青铜, φ0.46mm;
3. 圆针电镀: 镍底, 表面全部镀金;
4. 插入/拔出力: 30N Max.
5. 配合强度: 50N for 60s±5s.
6. 使用寿命: 最少750次插拔.

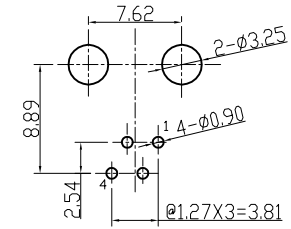
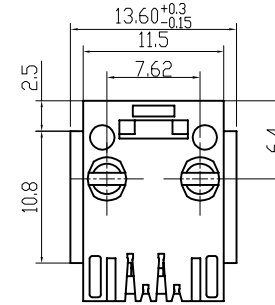
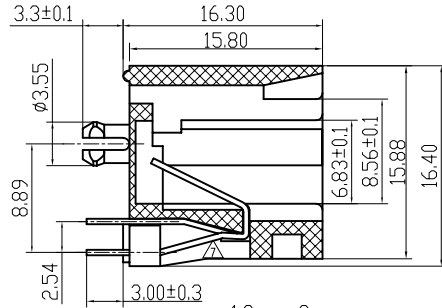
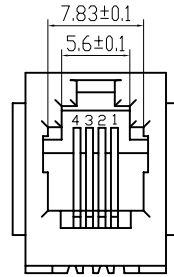

PCB LAYOUT COMPONENT SIDE  
TOLERANCES ±0.05 Thickness=1.6mm

环境特性:

1. 储存温度: -40°C~+85°C相对湿度<80%.
2. 工作温度: -40°C~+85°C
3. 储存时间: 12个月
4. 波峰焊温度: 265 ± 5° 10秒.

NOTES:

ELECTRICAL:

1. VOLTAGE RATING : 125 VAC RMS.
2. CURRENT RATING : 1.5 AMPS@25°C
3. CONTACT RESISTANCE : 20 mΩ MAX.
4. INSULATION RESISTANCE : 1000 MΩ MIN @500VDC.
5. WITHSTAND VOLTAGE : CONTACT TO CONTACT : 1000V DC OR AC PEAK;  
: CONTACT TO SCREEN AND TEST PANEL : 1500V DC OR AC PEAK  
@0.5mA 50Hz or 60Hz a minnte.

ENVIRONMENTAL:

1. STORAGE TEMPERATURE : -40°C~+85°C RELATIVE HUMIDITY<80%
2. OPERATION TEMPERATURE : -40°C~+85°C
3. GUARANTEE PERIOD : 12 MONTHS
4. WAVE SOLDERING TEMPERATURE: 265 ± 5° 10S  
MATES WITH MODULAR PLUG CONFORMING TO IEC-60603 & TIA-1096

MECHANICAL:

1. HOUSING MATERIAL : PBT/PA66/PA46 UL94V-0.
2. CONTACT MATERIAL : PHOSPHOR BRONZE φ0.46mm
3. CONTACT PLATING : GOLD PLATING OVER NICKEL.
4. MATING/UNMATING FORCE: : 30N Max..
5. RETENTION STRENGTH : 50N for 60s ± 5s.
6. DURABILITY : 750 CYCLES MIN.

TOP TIP	P/N 料号	DESCRIPTION 描述	MATERIAL COLOR材质
△	10201644B003	B522N-4403-M002 RJ22 1x1 5222 4P4C WITH EAR W/O GRID//5222插座 4P4C 3U (有耳香菇脚无网)	PBT WHITE 白
△	10201644C007	B522N-4406-U002 RJ22 1x1 5222 4P4C WITH EAR W/O GRID//5222插座 4P4C 6U (有耳香菇脚无网)	PA66 BLACK 黑
△	10201644A006	B522N-44GF-M014 RJ22 1x1 5222 4P4C WITH EAR W/O GRID//5222插座 4P4C G/F (有耳香菇脚无网)	PBT BLACK 黑
△	10201642A001	B522N-42GF-M005 RJ22 1x1 5222 4P2C WITH EAR W/O GRID//5222插座 4P2C G/F (有耳香菇脚无网)	PBT GRAY 灰
△		B522N-4430-R002 RJ22 1x1 5222 4P2C WITH BAR W/O GRID//5222插座 4P4C 钽金30U (有耳香菇脚无网)	PA46 BLACK 黑
△	10201644C010	B522N-4406-M004 RJ22 1x1 5222 4P4C WITH BAR W/O GRID//5222插座 4P4C 6U (有耳香菇脚无网)	PBT BLACK 黑
△	10201644A004	B522N-44GF-U006 RJ22 1x1 5222 4P4C WITH BAR W/O GRID//5222插座 4P4C G/F (有耳香菇脚无网)	PA66 BLACK 黑
△	10201644B012		
		RJ22 1x1 5222 4P4C WITH BAR W/O GRID//5222插座4P4C 3u" (有耳香菇脚无网)	PA46 BLACK 黑

RoHS Compliant

**CZT** 温州惠华接插件股份有限公司  
WENZHOU YIHUA CONNECTOR CO., LTD

TOLERANCES 公差  
00~15 ± 0.15  
15~30 ± 0.20  
30~ ± 0.25  
ANGLES ±1°

Material: 材质 SEE\_NOTE  
Finish: 电镀 SEE\_NOTE  
SHEET 1 OF 2 第 页 共 页

Designed: 设计 陈智艳  
Checked: 审核  
Approved: 核准

NAME: 名称 RJ22 1X1 5222 4P (WITH GRID& EAR) JACK  
DWG NO: 图号 E52QWY-1006-31  
PART NO: 料号 SEE\_NOTE

REV. 版本 08

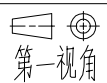

SCALE 比例 1:1  
UNIT 单位 mm  
CUSTOMER: 客户  
MODEL NO: 料号

受控编号: QR03-09

电气特性:

1. 额定电压: 125 VAC RMS
2. 额定电流: 1.5 AMPS@25°C
3. 接触电阻: 20mΩ MAX.
4. 绝缘电阻: 1000 MΩ MIN. @500 VDC
5. 耐压强度: : CONTACT TO CONTACT :1000V DC OR AC PEAK;  
: CONTACT TO SCREEN AND TEST PANEL :1500V DC OR AC PEAK  
@0.5mA 50Hz 或 60Hz 一分钟.

机构特性:

1. 塑壳材质: PA46, UL94V-0;
2. 圆针材质: 磷青铜, φ0.46mm;
3. 圆针电镀: 镍底, 表面全部镀金;
4. 插入/拔出力: 30N Max.
5. 配合强度: 50N For 60s±5s.
6. 使用寿命: 最少750次插拔.

环境特性:

1. 储存温度: -40°C~+85°C相对湿度<80%.
2. 工作温度: -40°C~+85°C
3. 储存时间: 12个月
4. 波峰焊温度: 265±5° 10秒.

NOTES:

ELECTRICAL:

1. VOLTAGE RATING : 125 VAC RMS.
2. CURRENT RATING : 1.5 AMPS@25°C
3. CONTACT RESISTANCE : 20 mΩ MAX.
4. INSULATION RESISTANCE : 1000 MΩ MIN @500VDC.
5. WITHSTAND VOLTAGE : CONTACT TO CONTACT :1000V DC OR AC PEAK;  
: CONTACT TO SCREEN AND TEST PANEL :1500V DC OR AC PEAK  
@0.5mA 50Hz or 60Hz a minnte.

MECHANICAL:

1. HOUSING MATERIAL : PA46 UL94V-0.
2. CONTACT MATERIAL : PHOSPHOR BRONZE φ0.46mm.
3. CONTACT PLATING : GOLD PLATING OVER NICKEL.
4. MATING/UNMATING FORCE: : 30N Max.
6. RETENTION STRENGTH : 50N for 60s±5s.
7. DURABILITY : 750 CYCLES MIN.

ENVIRONMENTAL:

1. STORAGE TEMPERATURE : -40°C~+85°C RELATIVE HUMIDITY<80%
  2. OPERATION TEMPERATURE : -40°C~+85°C
  3. GUARANTEE PERIOD : 12 MONTHS
  4. WAVE SOLDERING TEMPERATURE: 265±5° 10S
- MATES WITH MODULAR PLUG CONFORMING TO IEC-60603 & TIA-1096

REV. 版本	ECN NO. 变更说明	DATE 日期
08	切耳送样	2014.05.10

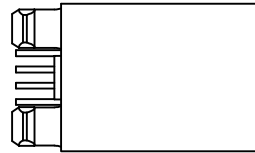
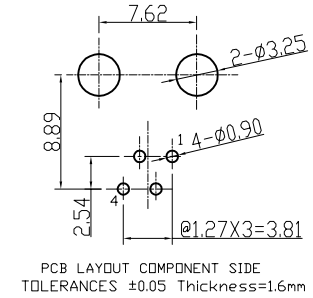
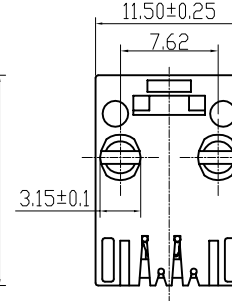
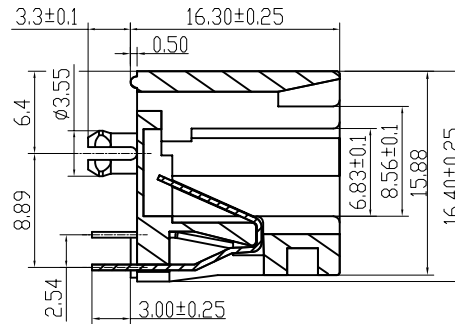
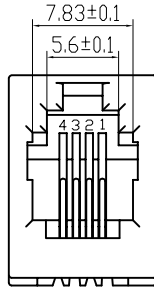
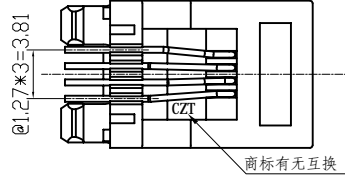

P/N 料号	DESCRIPTION 描述	MATERIAL COLOR 材质 商标	SALT SPRAY	MODEL NO.
10201644C016	RJ22 1x1 5222 4P4C WITH EAR W/O GRID//5222插座 4P4C 6u" (无耳香菇脚无网)	PA46 BLAKC 黑	CZT 24H	14080332

RoHS Compliant

**CZT**® 温州意华接插件股份有限公司  
WENZHOU YIHUA CONNECTOR CO., LTD

TOLERANCES 公差  
00~15 ± 0.15  
15~30 ± 0.20  
30~ ± 0.25  
ANGLES ±1°

Material: 材质	SEE_NOTE	Designed: 设计	陈智艳	NAME: 名称	RJ22 1X1 5222 4P (WITH GRID W/D EAR) JACK
Finish: 电镀	SEE_NOTE	Checked: 审核		DWG NO: 图号	E52QWY-1006-31
SHEET 2 OF 2 第 页 共 页		Approved: 核准		PART NO: 料号	SEE_NOTE
					REV. 版本
					08

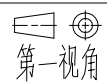

A4  
SCALE 比例 1:1  
UNIT 单位 mm

CUSTOMER: 客户  
MODEL NO: 料号